

Plus Series LR30KPlus 30 kN Universal Materials Testing Machine

The LR30KPlus advanced materials testing machine incorporates an extensive range of features making it ideal for performing complex as well as routine testing applications up to 30 kN (6744 lbf). The standard LR30KPlus features a twin column design with a crosshead travel range of 870 mm (34.3 in). Extended machine column options (LR30KPlus-E models) for testing high elongation materials are also available.

This bench mounted machine is microprocessor controlled and incorporates world proven 32 bit technology for highly accurate load measurement and rapid data acquisition. The LR30KPlus features an integral user interface consisting of a side mounted control console with large, positive action membrane keys, allowing complex tests to be performed at the touch of a button. A back lit 4 line LCD display shows the test and set up information in a wide choice of user selectable languages and units.

The stand alone system is capable of storing up to 600 test results from a choice of ten programmable

test set ups. Test parameters are entered using the keypad in a sequential menu driven format.

For additional flexibility, the LR30KPlus can also be connected to a personal computer with optional Lloyd Instruments NEXYGEN™ MT material test and control software. NEXYGEN software provides almost unlimited testing and results processing capability in a familiar Windows environment.

The high stiffness frame incorporates a crosshead guidance system to prevent side loading of the sample under test. The crosshead is driven by twin lead screws and a high precision servo motor and DC servo system to achieve a wide range of speeds throughout the full load range.

A series of highly accurate, interchangeable load cells is available for tension, compression and cycling through zero force measurements. Our extensive range of grips and fixtures support virtually any type of test. The system is ideal for use in production, quality control, education and research environments.

Features

- Simple to set up, operate and maintain
- High accuracy load measurement (0.5% of reading)
- Constant load holding
- Data sampling rate 8 kHz
- Load rate control
- Saves up to 600 test results
- 10 programmable test set ups
- Pre-loading of samples and cycling to load or extension limits
- Multi-stage testing with NEXYGEN MT software
- Extension resolution < 0.05 micron
- Multi-lingual display options
- Multi-unit display options
- Flash upgradeable
- Extended column options for testing high extension materials
- Wide selection of load cells, grips, jigs, extensometers, temperature chambers and other accessories

Specifications

Force Capacity:	
LR30KPlus	30 kN (6744 lbf)
LR30KPlus-E	30 kN (6744 lbf)
Crosshead Speed:	0.001 to 508 mm/min (0.0004 to 20 in/min)
Speed Accuracy:	< 0.2%
Travel:	
LR30KPlus	870 mm (34.3 in)
LR30KPlus-E	1370 mm (53.9 in)
Width Between Columns:	404 mm (15.9 in)
Load Resolution:	< 0.005% of load cell used (max.)
Load Cell Accuracy:	± 0.5% of reading
Extension Resolution:	< 0.05 micron
Data Sampling Rate:	8 kHz
Display:	40 character x 4 line backlit LCD
Extensometer Inputs:	Digital and Analogue Extensometer
Data Outputs:	Digital - RS232, Analogue 10V dc max (optional)
Load Measuring System:	Exceeds the requirements of BS EN ISO 7500-1, ASTM E4, DIN 51221
Analysis Software:	NEXYGEN MT Data Analysis Software and Ondio Applications Builder Software (optional)
Supply Voltage:	115/230V ac ± 10%, 50-60 Hz
Weight:	150 kg (330 lb)
Operating Temperature:	5° to 35° C (40° to 95° F)



Accessories

Item	Part No	Item
XLC Series Load Cells:		Extensometers:
5 N (1.12 lbf)	01/2946	We supply contacting and non-contacting extensometers. For further information see our extensometer specification sheets.
10 N (2.25 lbf)	01/2360	
20 N (4.5 lbf)	01/2950	
50 N (11.25 lbf)	01/2361	
100 N (22.5 lbf)	01/2480	
250 N (56.25 lbf)	01/3048	
500 N (112.5 lbf)	01/2362	Temperature Chambers and High Temperature Furnaces:
1000 N (225 lbf)	01/2419	A range of thermal chambers and furnaces are available. For further information see our specification sheets.
2500 N (562.50 lbf)	01/2363	
5000 N (1124 lbf)	01/2364	
10 kN (2248 lbf)	01/2365	Splinter Shields:
20 kN (4496 lbf)	01/2417	Splinter shields can be supplied to your specific requirements. Contact Lloyd Instruments for further information.
30 kN (6744 lbf)	01/2366	
Application Software:		LR30K Plus-CC Large Compression Cage Option:
NEXYGEN™ MT	40/0658	The LR30K Plus machine can be ordered mounted above a floor standing compression cage for larger sample testing. Contact Lloyd Instruments to discuss your specification needs.
NEXYGEN™ MT/Ondio software suite	40/0695	
Grips & Fixtures:		
A wide range of grips and fixtures are available. For further information see our grip specification sheets.		

Machine Dimensions

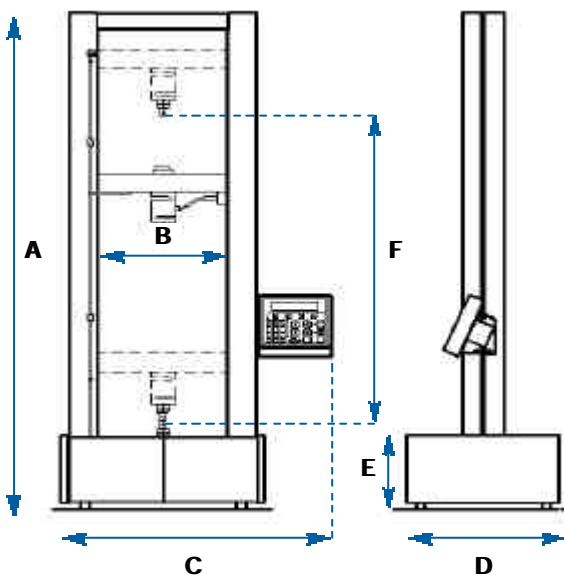

	mm	in
A (Standard machine height)	1567	61.7
B	404	15.9
C	871	34.3
D	596	23.5
E	242	9.5
F (Standard machine travel)	870	34.3
F (Extended machine travel)	1370	53.9



Tensile test



Compression test



Flexure test

Ordering Information

Model	Part No	Capacity	Description
LR30K Plus	01/3160	30 kN (6744 lbf)	LR30K Plus machine with Console - standard 870 mm (34.3 in) travel
LR30K Plus-E	01/3192	30 kN (6744 lbf)	LR30K Plus machine with Console - extended 1370 mm (53.9 in) travel

AMETEK
TEST & CALIBRATION INSTRUMENTS



www.ametek.com

UK
Lloyd Instruments Ltd
12 Barnes Wallis Road
Segensworth East, Fareham
Hants, PO15 5TT

Tel +44 (0)1489 486 399
Fax +44 (0)1489 885 118
E-mail general@lloyd-instruments.co.uk
Web www.lloyd-instruments.co.uk

USA
AMETEK TCI Division
8600 Somerset Drive
Largo
Florida 33773

Tel +1 (727) 536 7831
Fax +1 (727) 539 6882
E-mail chatillon.fl-lar@ametek.com
Web www.lloyd-instruments.co.uk

Far East
AMETEK Singapore Pte Ltd
10 Ang Mo Kio Street 65
#05-12 Techpoint
SINGAPORE 569059

Tel +65 6484 2388
Fax +65 6481 6588
E-mail aspl@ametek.com.sg
Web www.lloyd-instruments.co.uk

France
Lloyd Instruments S.A.S.
3, Avenue des Coudriers
Zone d'activité de l'observatoire
78180 Montigny Le Bretonneux

Tel +33 (0)1 30 57 47 74
Fax +33 (0)1 30 57 50 33
E-mail general@lloyd-instruments.com
Web www.lloyd-instruments.fr

Germany
AMETEK GmbH
Rudolf-Diesel-Straße 16
D-40670 Meerbusch

Tel +49 (0)2159 9136-70
Fax +49 (0)2159 9136-80
E-mail info@ametek.de
Web www.ametek.de