

These manually operated torque test stands are ideal for a wide variety of applications requiring up to 100 lbFin of torque, including closure torque testing, fastener torque testing, and more. The TST's modular design allows it to be configured for a variety of torque sensors and gripping fixtures. Ultra-smooth hand wheel operation ensures ease of use and a lever-operated slider with travel stops makes engaging and disengaging samples quick and efficient. The stand includes a torque loading plate with tapped holes for grip and custom fixture mounting and an angle dial indicator with 2° resolution and unlimited angular travel.

## Specifications

Load capacity:	100 lbFin [11.3 Nm]
Maximum angular travel:	No limit
Angular rate:	12° per hand wheel revolution
Angle indicator resolution:	2°
Maximum slider travel:	15.5 in [394 mm]
Slider travel rate:	1.047 in [26.6 mm] per lever revolution
Weight (w/o optional equipment):	
TST:	33 lb [15 kg]
TSTH:	27 lb [12.3 kg]
Included accessories:	Tool kit
Warranty:	3 years (see individual statement for further details)

>> Rotating torque plate has a matrix of tapped holes for grip or fixture mounting



## Optional Equipment

Digital angle indicator TST001	Displays cw or ccw angle with 0.1° resolution for approximately 278 rotations, resettable with zero button. Accurate to ±0.7°. Three sets of mounting holes allow the indicator to be mounted perpendicular to, or parallel to the test stand column. It can also be repositioned along the column.
Torque sensor	Series STJ sensors are recommended for use with Mark-10 torque test stands. A wide range of capacities is available. Mounts directly to the test stand. Other sensors and mounting adapters are available.
Force/torque indicator BGI	Displays reading from the torque sensor. Includes features such as data outputs, data averaging, set points, and more.
Torque gauge Series MGT	Basic torque gauge for various applications.
Grips	Various universal and application-specific grips are available

>> Digital angle indicator



TST



The TST is shown set up for a test, with Series STJ torque sensor, BGI force/torque indicator, and G1022 Jacobs chuck grip

TSTH

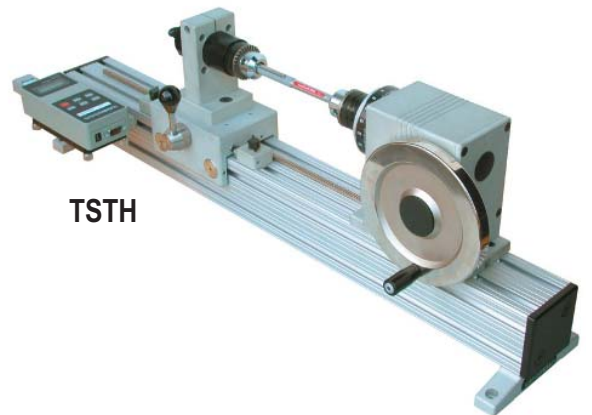

The TSTH is shown testing pen cap torque, with a Series STJ torque sensor, BGI force/torque indicator, and G1022 Jacobs chuck grip

## Dimensions

in [mm]

### TST

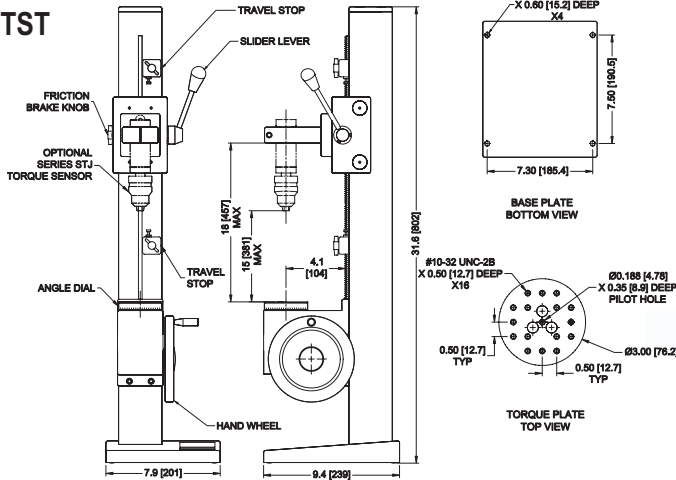

### TSTH

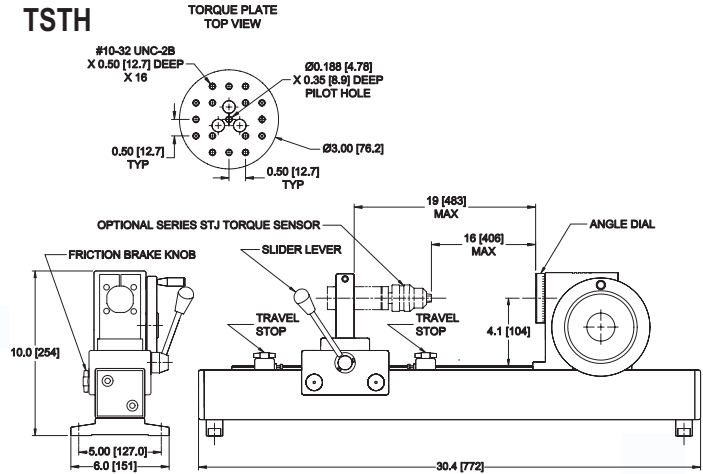

## Ordering Information

Model No.	Description
TST	Torque test stand, vertical, lever-operated, 100 lbFin
TSTH	Torque test stand, horizontal, lever-operated, 100 lbFin
TST001	Digital angle display
STJ <sup>1</sup>	Universal torque sensor
BGI	Universal force/torque indicator
MGT <sup>2</sup>	Digital torque gauge

TST / TSTH test stands include a wrench set and AC1004 adjustable gauge mounting plate (for BGI or MGT).

1. Series STJ torque sensors are available in a wide range of capacities, from 10 ozin to 100 lbin (7 Ncm to 1150 Ncm), and mount to the TST / TSTH without extra adapters. Other sensors and mounting adapters are available.
2. Series MGT torque gauges are available in a wide range of capacities, from 10 ozin to 100 lbin (7 Ncm to 1150 Ncm), and mount to the TST / TSTH without extra adapters.