

32-1044 REV 2



The Series MG Digital Force Gauge is an economical instrument for push and pull testing up to 500 lbF. A rugged reversible aluminum housing allows for hand-held use or test stand mounting. Three pushbuttons allow the user to easily select units of measurement, reset zero, and recall tensile and compressive peak loads. The MG is compatible with all Mark-10 force measurement test stands and gripping fixtures.

Specifications

Accuracy:	±0.5% of full scale
Power:	AC or non-rechargeable 9V battery, with Intelligent Power Management System (IPM). IPM warns the user via a "LO BAT" indicator and then will power off the gauge.
Battery life:	30 hours of continuous use
Selectable units of measurement:	lbF, N, kg/g (depending on model)
Load cell deflection (at full scale):	See Ordering Information
Safe overload:	150% of full scale (display shows "----" at 110% and above)
Weight (gauge only):	MG012 - MG200: 0.7 lb [0.3 kg], MG500: 0.87 lb [0.4 kg]
Environmental requirements:	40° F - 100° F [5° C - 45° C], <96% humidity (non-condensating)
Thermal effects:	Zero: 0.03% of full scale/°C, Span: 0.01% of full scale/°C
Housing construction:	Aluminum
Included accessories:	Hook, flat
Warranty	3 years (see individual statement for further details)

Features

Compact design	Portable and flexible in a wide range of applications
Push-button calibration	Simple and quick calibration procedure
Peak memory	For tension and compression
Selectable units of measurement	Measure in lbF, N, or kg/g (depending on model)
Reversible housing	Housing can be reversed for handheld or test stand use

Ordering Information

Model No.	Capacity x Resolution	Deflection
MG012	0.12 x 0.0001 lbF, 50 x 0.05 gF, 0.5 x 0.0005 N, 110V	0.005 [0.13]
MG025	0.25 x 0.0002 lbF, 100.00 x 0.1 gF, 1 x 0.001 N, 110V	0.010 [0.25]
MG05	0.5 x 0.0005 lbF, 250 x 0.2 gF, 2.5 x 0.002 N, 110V	0.010 [0.25]
MG2	2 x 0.002 lbF, 1 x 0.001 kgF, 10 x 0.01 N, 110V	0.009 [0.23]
MG5	5 x 0.005 lbF, 2.5 x 0.002 kgF, 25 x 0.02 N, 110V	0.005 [0.13]
MG10	10 x 0.01 lbF, 5 x 0.005 kgF, 50 x 0.05 N, 110V	0.010 [0.25]
MG20	20 x 0.02 lbF, 10 x 0.01 kgF, 100 x 0.1 N, 110V	0.004 [0.10]
MG50	50 x 0.05 lbF, 25 x 0.02 kgF, 250 x 0.2 N, 110V	0.010 [0.25]
MG100	100 x 0.1 lbF, 50 x 0.05 kgF, 500 x 0.5 N, 110V	0.010 [0.25]
MG200	200 x 0.2 lbF, 100 x 0.1 kgF, 1000 x 1 N, 110V	0.010 [0.25]
MG500	500 x 0.5 lbF, 250 x 0.2 kgF, 2500 x 2 N, 110V	0.010 [0.25]

All models include 110V AC adapters. Add suffix 'E' for euro plug (220V), 'U' for UK plug (220V), or 'A' for Australian plug (220V).

Ex: MG-50E, MG-200U, MG-500A

Dimensions

in [mm]

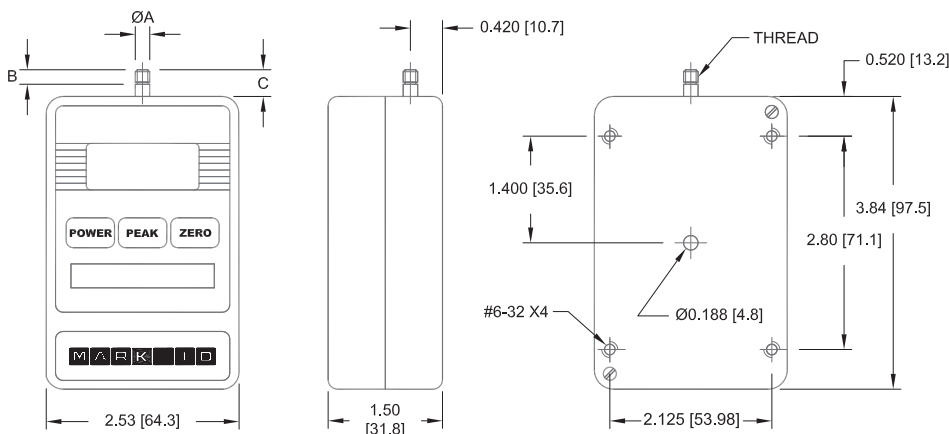

	MG012 - MG200	MG500
ØA	0.200 [5.8]	0.375 [9.5]
B	0.19 [4.8]	0.44 [11.2]
C	0.35 [8.9]	0.68 [17.3]
Thread	#10-32	5/16-18



Distributed by:

Nels Jorgenson & Co. ■ 20400 Nine Mile Road ■ St. Clair Shores, MI 48080

Tel: 586-774-6600 ■ Fax: 586-774-6605 ■ www.njforce.com ■ njc@njforce.com