

MT SERIES

Modular Mechanical Test Stands

The MT Series Mechanical test stands are an easy-to-use solution for force measurement applications up to 500 lbf (2.2 kN) capacities. Two capacities are available: 150 lbf (660 N) and 500 lbf (2.2 kN). Either capacity test stand can be equipped with a quick-action lever or precision hand-wheel for controlling crosshead speed and travel. The MT test stand can be bench mounted, wall mounted or positioned horizontally. Vertical working lengths are available from 750mm (29 inch), 1000mm (39 inch) and 1500mm (60 inch). Standard stroke is 6 inches (150mm). Larger stroke is available as a special by extending the length of the precision rack.

The MT Series features an innovative design that maximises working space and that simplifies operation and maintenance. The single column design with 150mm (6 in) throat is ideal for large specimens. The removal platen is designed to accommodate metric and imperial threaded fixtures. Special gauge adapter kits simplify gauge alignment. Options include a column ruler, graduated in millimetres and inches. Analog travel indicators are also optionally available. Travel resolution may be displayed up to 0.01mm (0.0005 in).

FEATURES

- For tensile and compression testing
- Large work area
 - 150mm (6 in) throat for large specimens
 - Universal Fixturing (Metric or Imperial)
 - 150mm (6 in) stroke (Larger strokes available)
- Modular design
 - Bench, Horizontal or Wall mounted
 - Lever or Handwheel Operation
 - Multiple Travel Lengths
 - Kits for Field Modifications

SPECIFICATIONS

Capacities:

MT-150	150 lbf (660 N)
MT-500	500 lbf (2.2 kN)

Loading Method:	Quick-Action lever or Precision Handwheel
------------------------	-------------------------------------------

Travel Rates:

Lever Revolution	75mm (3 in) per
Handwheel Revolution	12mm (0.5 in) per

Vertical Clearance:

Standard	750mm (29.5 inch)
Extended	1000mm (39.4 inch)
Ultra	1500mm (59 inch)

Stroke:	6 inch (150mm) Longer strokes available
----------------	--------------------------------------------



SPECIFICATION
SS-FM-3133-0702
July 2002

INTERNET

www.ametek.com
www.chatillon.com
www.lloyd-instruments.co.uk

AMETEK, CHATILLON and NEXYGEN are registered trademarks of AMETEK, Inc.
LLOYD INSTRUMENTS is a trademark of AMETEK, Inc.

Copyright 2000, by AMETEK, Inc.

Chatillon
A registered trademark of AMETEK, Inc.

Ordering Information

Order No. Description

BASE Model Number - 1st thru 5th Characters
 MT150L CHATILLON MT Series Mechanical Tester, 150 lbf (660 N), Lever Actuated
 MT150H CHATILLON MT Series Mechanical Tester, 150 lbf (660 N), Handwheel Actuated
 MT500L CHATILLON MT Series Mechanical Tester, 500 lbf (2.2 kN), Lever Actuated
 MT500H CHATILLON MT Series Mechanical Tester, 500 lbf (2.2 kN), Handwheel Actuated

Travel Length - 6th Character
 S Standard, 750 mm (29.5 in)
 E Extended, 1000 mm (39.4 in)
 U Ultra, 1500 mm (59 in)

Force Gauge Mounting Kit - 7th Character
 1 DPP Series Force Gauge
 2 DPPH Series Force Gauge
 3 DFM Series Force Gauge
 4 DFIS Series Force Gauge
 5 DFGS Series Force Gauge
 6 DFT Series Force Gauge
 7 DFA Series Force Gauge
 X Not Required

Mounting Style - 8th Character
 B Bench Vertical Mounting
 H Bench Horizontal Mounting
 W Wall Mounting

Options - 11th thru 13th Characters
 1 Analog Travel Indicator
 X None Required

MT150L S 1 B 1 Sample Order Number - (MT150LS1B1)
 CHATILLON MT150 Series (150 lbf), standard 750mm (29 in) travel with DPP Series mounting kit. Vertical bench mounting style with right-hand lever operation. Optional analogue travel indicator supplied.



150 lbf (660 N) lever actuated
MT Series Mechanical Tester



150 lbf (660 N) handwheel actuated
MT Series Mechanical Tester



500 lbf (2.2 kN) lever actuated
MT Series Mechanical Tester



500 lbf (2.2 kN) handwheel actuated
MT Series Mechanical Tester

Machine Dimensions

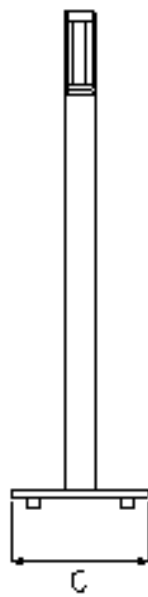
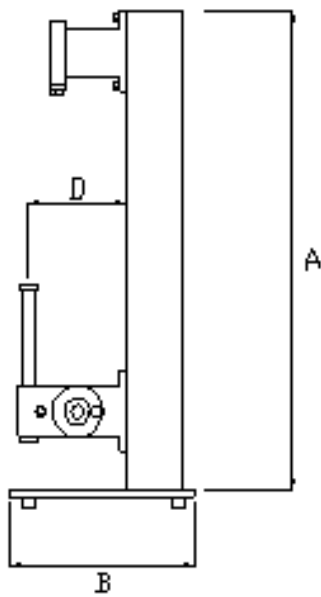

	mm	inches
A	750, 1000, 1500	29.5, 39.4, 59.1
B	290	11.4
C	215	8.5
D	152	6

150lbf and 500lbf MT Series Mechanical Tester, handwheel actuated.

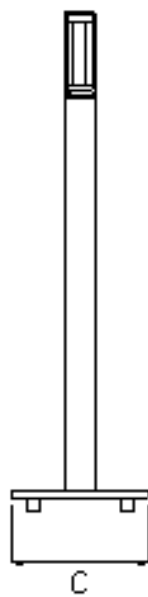
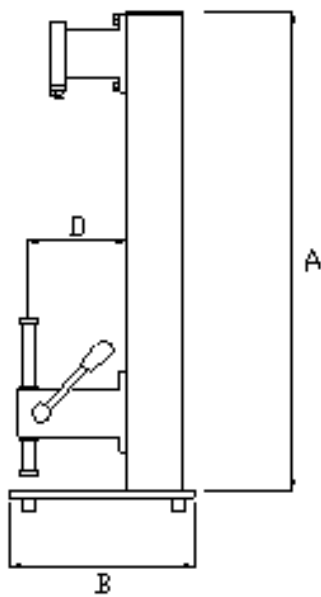

150lbf and 500lbf MT Series Mechanical Tester, lever actuated.

Standard Accessories (Included)

NC002660	User Manual	
17159	Hook	(Hook assembly for MT150)
17160	Coupling	(Hook assembly for MT150)
13053	Hook	(Hook assembly for MT500)
13048	Coupling	(Hook assembly for MT500)
17012	Compression platen (3" diameter)	
NC002686	5/16-18 Set Screw	(Attaches compression platen or hook to rack on stand)
NC002292	Warranty Card	

Optional Accessories - Column lengths

SPK/MT/0750	750mm Column
SPK/MT/1000	1000mm Column
SPK/MT/1500	1500mm Column

Optional Accessories - Gauge Mounting Kits

SPK/MT/0001	Gauge Mounting Kit, DPP Series
SPK/MT/0002	Gauge Mounting Kit, DPPH Series
SPK/MT/0003	Gauge Mounting Kit, DFM Series
SPK/MT/0004	Gauge Mounting Kit, DFIS Series
SPK/MT/0005	Gauge Mounting Kit, DFGS Series
SPK/MT/0006	Gauge Mounting Kit, DFT Series
SPK/MT/0007	Gauge Mounting Kit, DFA Series

Optional Accessories - Mounting Kits

SPK/MT/HORZ	Horizontal Mounting Kit
SPK/MT/WALL	Wall Mounting Kit

Optional Accessories - Load Actuation Method

SPK/MT/L500	Lever Actuation Module, 500lbf
SPK/MT/L150	Lever Actuation Module, 150lbf
SPK/MT/H500	Hand Wheel Actuation Module, 500lbf
SPK/MT/H150	Hand Wheel Actuation Module, 150lbf

Optional Accessories - Travel Indicators

SPK/MT/ADT1	Dial Travel Indicator, Analogue
-------------	---------------------------------

Optional Accessories - Test Stand Accessories

SPK/MT/GBLK	Gauge Mounting Block
SPK/MT/BASE	Base Plate Assembly
SPK/FMG/012A	Hook, #10-32, 50lbf
SPK/FMG/012B	Hook, #10-32, 100lbf
SPK/FMG/012C	Hook, 5/16-18, 500lbf



TEST AND CALIBRATION INSTRUMENTS

UK
Lloyd Instruments Ltd
Forum House
12 Barnes Wallis Rd
Segensworth East, Fareham
Hampshire, UK
PO15 5TT
Tel: +44 (0)1489 486 399
Fax: +44 (0)1489 885 118

America
AMETEK TCI Division
8600 Somerset Drive
Largo
Florida 33773
USA
Tel: +1 (727) 536 7831
Fax: +1(727) 539 6882

Far East
Lloyd Instruments
Far East Representative Office
No7 Sherwood Place
Alexander Heights
6064 Perth
WESTERN AUSTRALIA
Tel: +61 8 9343 5725
Fax: +61 8 9343 5723

France
Lloyd Instruments SA
3 avenue des Coudriers
Zone d'activite de l'observatoire
78180 Montigny-Le-Bretonneux
FRANCE
Tel: +33 (0) 1 30 57 47 74
Fax: +33 (0) 1 30 57 50 33

Germany
AMETEK Precision Instruments
Europe GmbH
Rudolf-Diesel-StraÙe 16
D-40670 Meerbusch
GERMANY
Tel: +49 (0)2159 9136-70
Fax: +49 (0)2159 9136-80

email: general@lloyd-instruments.co.uk
www.lloyd-instruments.co.uk

Information within this document is subject to change without notice.

ISO 9001
Manufacturer